



INTRODUCING CMAA

The Crane Manufacturers Association of America, Inc. (CMAA), is an independent trade association affiliated with the United States Division of Material Handling Industry. The voluntary association of CMAA members has existed since 1955. Member companies have been and are industry leaders today.

CMAA member companies are concerned, conscientious manufacturers who have come together in an industry association for the purpose of providing voluntary standards for mechanical, structural and electrical design of cranes, as well as formulating guidelines for the proper use, operation and maintenance of those cranes. Members donate countless hours of their time toward these earnest efforts.

Member companies of the Crane Manufacturers Association of America, Inc., meet regularly to review, discuss and revise the standards for design, performance and proper operation of engineered crane systems. CMAA member companies have committed to the development, maintenance and publishing of industry standard specifications for Top Running, Under Running, Single and Multiple Girder Cranes.

Crane Manufacturers Association of America, Inc.
8720 Red Oak Boulevard, Suite 201
Charlotte, NC 28217-3992
Ph.: (704) 676-1190
Fax: (704) 676-1199
www.mhia.org/cmaa

Selecting the Right Overhead Crane

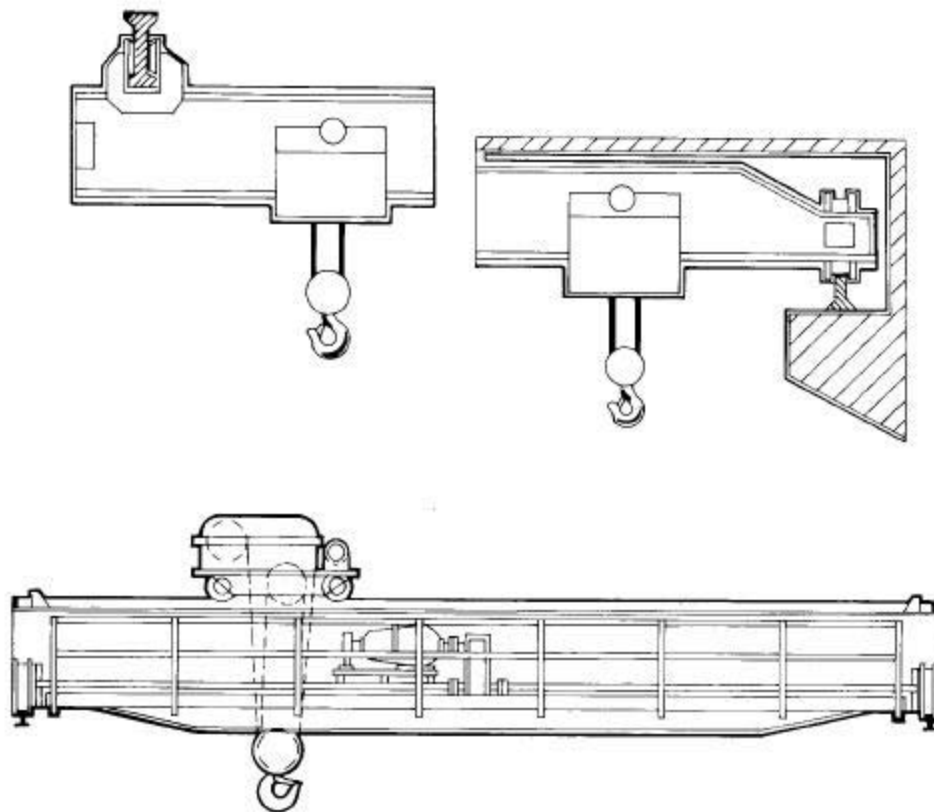

An Affiliated Trade Association of





SELECTING THE RIGHT OVERHEAD CRANE

The selection of the proper overhead crane system is critical to the safe and economical operation of your facility. The owner is responsible for selecting a qualified crane supplier.

CMAA member companies are well qualified to help you make the proper overhead crane investment decision.

FACTORS TO BE CONSIDERED IN PROPER OVERHEAD CRANE SELECTION:

Application

Material Handling
Single or Double Girder
Load Rating (capacity)
Service Rating (freq. of operation)
Control / Speed
Top Running or Under Running
Electric, Air, Manual
Impact on Production

Facility

Clearance Requirements
Building Width / Crane Span
Building Length
Low Obstruction / Crane Hook Height
Runway Beams / ASCE Rail
Column Supports
Environment
Maintenance Access / Service Platforms

Safety Considerations

For greater detail consult CMAA specifications #70 and #74 or contact CMAA.

Since 1955 CMAA member companies have worked together in developing and refining crane specifications and standards to assure proper selection and application of cranes.

CMAA member companies have the engineering and design expertise to assist you in selecting the proper overhead crane for your applications.



INSTALLATION AND START-UP OF YOUR NEW OVERHEAD CRANE

Proper installation, start-up and testing of the selected crane is important for long term satisfaction with your crane investment.

CMAA member companies are prepared to assist you in all phases of the crane buying and installation processes.



ADDITIONAL OWNER RESPONSIBILITIES

Having selected and installed an overhead crane to CMAA specifications and standards, the owner is responsible for the following:

Training

All overhead crane operators must be trained prior to using any crane.

Training includes but is not limited to:

- Familiarization with crane controls
- Capacities of cranes
- Safe operating practices (refer to CMAA's training program)

Periodic operator retraining is strongly recommended. Training should be conducted in accordance with the crane manufacturers' recommendations and CMAA's ***Crane Operators Manual***.

CMAA's video training program ***The Fundamentals of Overhead Crane Safety*** provides a complete training package and includes the materials necessary to develop an in-house overhead crane safety program. The package includes a 45-minute training video and essential training materials (including a safety checklist and valuable training literature).

Inspection

OSHA standards (OSHA 1910.179) require cranes be inspected on a daily, monthly and yearly basis. Additional inspections may be required due to hours of operation, environment and/or severity of service. The inspection requirements of ANSI (B30.2, B30.11 and B30.17) and the manufacturer must also be followed.

CMAA has available a comprehensive inspection list that may be obtained from the CMAA office or a CMAA member company.

Maintenance

OSHA regulation, 1910.179 and ANSI B30, require that all crane owners shall maintain their cranes in safe operating condition and retain appropriate maintenance records.

Operation

Overhead crane owners are responsible for the proper operation and use of their cranes and must follow OSHA regulations 1910.197, B30 and ANSI.

For Example:

- Manufacturers capacity rating must never be exceeded
- Unsafe components must be replaced
- Loads must never be suspended over personnel
- Proper rigging practices must be followed

Consult CMAA's ***Crane Operators Manual*** for additional recommended operating practices.

CMAA member companies can provide service or advice in the proper training of your personnel, inspection and maintenance of your cranes.



Goals and Purpose

The Crane Manufacturers Association of America, Inc. (CMAA) is an affiliate of Material Handling Industry. CMAA actively promotes efficient overhead crane design, applications, safety and maintenance by producing standards and educational materials such as literature and audio/visuals.

For more information regarding this brochure or CMAA please contact or write:

**Crane Manufacturers Association of America, Inc.
8720 Red Oak Boulevard, Suite 201
Charlotte, North Carolina 28217-3992**

**Phone: 800-345-1815
704-676-1190**

Fax: 704-676-1199

URL: www.mhia.org/cmaa

To receive information about CMAA and its member companies contact:

CMAA c/o Material Handling Industry
8720 Red Oak Blvd., Suite 201
Charlotte, NC 28217-3992
Phone: 800-345-1815 / 704-676-1190 Fax: 704-676-1199
URL: www.mhia.org/cmaa

Call the Material Handling Institute Literature Department at 800-345-1815 or 704-676-1190 to order the following CMAA publications:

#10089 - CMAA Specification 70, *Specifications for Top Running Bridge & Gantry Type Multiple Girder Electric Overhead Traveling Cranes*

The purpose of this book is to provide a basis for uniform quality and performance. This specification contains information, which should be helpful to the purchasers and users of cranes and to the engineering and architectural professions. While much of this information must be of a general nature, the items listed may be checked with individual manufacturers and comparisons made which can lead to optimum selection of equipment.

#10090 - CMAA Specification 74, *Specifications for Top Running and Under Running Single Girder Electric Overhead Traveling Cranes Utilizing Under Running Trolley Hoist*

This book promotes standardization and provides a basis for uniform quality and performance. It contains information, which should be helpful for purchasers and users of cranes, as well as engineers and architects. Text consists of seven sections: general specifications, crane service classification, structural design, mechanical design, electrical equipment, crane inquiry data sheet and a glossary.

#10099 – *Crane Operator’s Manual*

This 29-page manual lists qualifications required to be a crane operator, as well as “shall and shall nots.” Safety is stressed by describing the best way to operate a crane. It also explains why a crane should be operated safely. The safety suggestions are intended to supplement company safety practices and crane manufacturers’ instructions.

#10102 – *Overhead Crane Inspection and Maintenance Checklist*

This checklist, published by the Crane Manufacturers Association of America, Inc., aids owners of overhead cranes when conducting periodic maintenance inspections. While the proper installation, operation, testing, and maintenance of cranes are a continuing responsibility of the owner/user in accordance with the current approved standards, this checklist provides a minimal list of components to be inspected regularly.

#10059 – *The Fundamentals of Overhead Crane Safety*

CMAA’s video training program ***The Fundamentals of Overhead Crane Safety*** provides a complete training package and includes the materials necessary to develop an in-house overhead crane safety program. The package includes a 45-minute training video and essential training materials (including a safety checklist and valuable training literature).